



CONTENTS

FEATURES PHYSICAL SPECIFICATIONS2

CAPACITY RATINGS(CHILLED WATER, HOT WATER).....3,4

HORIZONTAL CHILLING MOUNTED, EXPOSED.....5

HORIZONTAL CHILLING MOUNTED, CONCEALED.....6

LO-BOY.....7

SLANT TOP DISCHARGE.....8

NOMENCLATURE

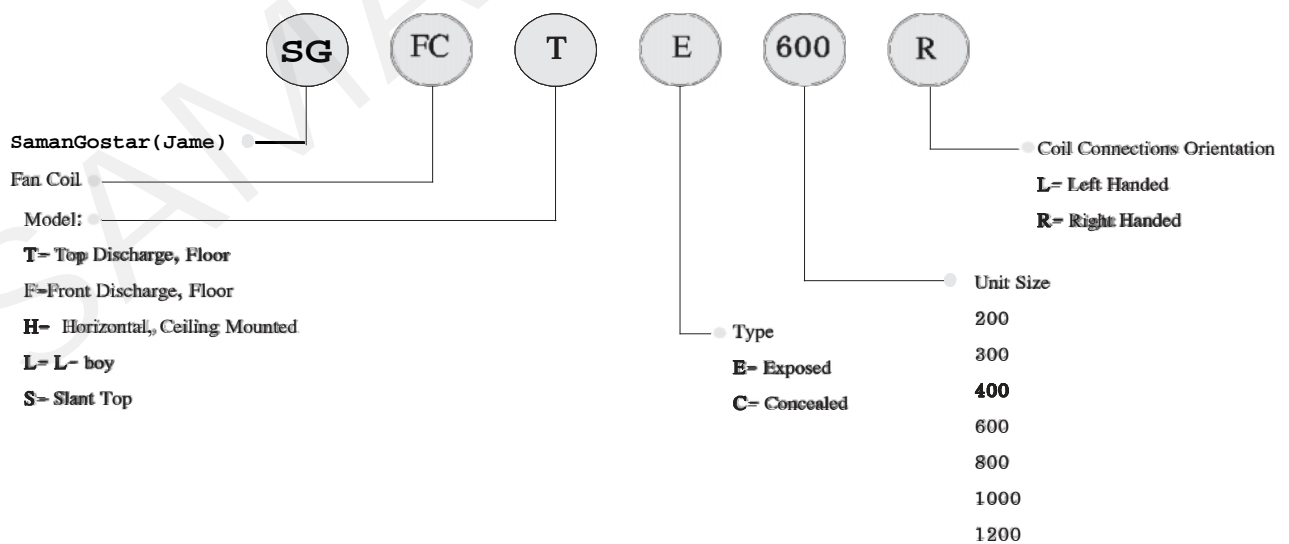



FEATURES

Elegant Silhouette in assorted Colors

Rigid Sheet metal construction, Rust Proofed. Phosphatized and Covered With Fine Quality Enamed.

Insulated Front Panel Attenuates Equipment sound And Prevents Heat Loss. Heavy Gauge Galvanized Condensate Pan covered With A Layer Of Bitument. High Performance Double Width. Double Inlet Forward Curved Centrifugal fans Made of ABS Material, Statically and dynamically Balancced. High Efficiency Coil Constructed From Copper Tubes And Corrugated plate Aluminum Fins.

3, speed 10/50HZ/220 V Electric Motors, Thermally Protected.

4, Position Rotary Manual Fan Switch (Off, Hi, Med, Low)

Easily Accessible, Washable Aluminum Filters.

2

PHYSICAL SPECIFICATIONS

Description	MODEL						
	200	300	400	600	800	1000	1200
Nominal Air Flow Rate (CFM)	200	300	400	600	800	1000	1200
* Unit Weight (Kg)	30	36	40	44	55	68	79
Number Of Motors	1	1	1	1	2	2	2
Nominal Power (W)	25	25	45	45	25&45	45	45
Total Rated Amps	0.4	0.4	0.65	0.65	1.05	1.3	1.3
Coil Face Area (Sqft)	0.97	1.40	1.63	1.92	2.51	3.17	4.00
Tube Size	3/8" O.D.						
No Of Rows	3						
No Of Fins/Inch	14						
Drain Connection	3/4" (Sweat Type)						

*Unit weights given are for exposed models. For concealed and lo-boy, reduce values by approximately 20%



CHILLED WATER RATINGS

MODEL	Entering Water Temperature (F)	GPM	Water Pressure Drop (FT.W.G.)	Entering Air Temperature (F)					
				63 WB .75 DB		65 WB .77 DB		67 WB .80 DB	
				Sensible Load (BTU/HR)	Total Load (BTU/HR)	Sensible Load (BTU/HR)	Total Load (BTU/HR)	Sensible Load (BTU/HR)	Total Load (BTU/HR)
SGFC-200	42	1.5	2.2	6000	7600	6200	8450	6500	9400
		2	3.6	6500	8200	6700	9250	7000	10400
		2.5	5.4	7000	8800	7200	9800	7500	11000
	44	1.5	2.2	5500	6800	5700	7700	6000	8700
		2	3.6	6000	7600	6200	8450	6500	9400
		2.5	5.4	6500	8200	6700	9100	7000	10000
46	1.5	2.2	4500	6200	5000	7000	5500	8000	
	2	3.6	5000	6600	5500	7500	6000	8600	
	2.5	5.4	5500	7300	6000	8300	6500	9400	
SGFC-300	42	2	4.4	8000	9800	8400	10900	9000	12000
		2.5	6.5	8500	10800	8700	11900	9500	13100
		3	9	9000	11200	9400	12350	10000	13700
	44	2	4.4	7500	8900	8000	9900	8500	11000
		2.5	6.5	8000	9600	8500	10700	9000	12000
		3	9	8500	10100	9000	11350	9500	12800
46	2	4.4	6500	7900	7200	8900	8000	10000	
	2.5	6.5	7000	8600	7700	9700	8500	11000	
	3	9	7500	9000	8200	10200	9000	11600	
SGFC-400	42	2.5	6.5	10500	12900	11000	14200	11500	15800
		3	9	11000	13500	11500	15000	12000	16600
		3.5	11.5	11500	14200	12000	15700	12500	17400
	44	2.5	6.5	10000	11600	10700	13000	11500	14400
		3	9	10500	12200	11200	13700	12000	15400
		3.5	11.5	11000	12800	11700	14350	12500	16000
46	2.5	6.5	9000	10400	9700	11800	11000	13400	
	3	9	9500	10900	10400	12400	11500	14000	
	3.5	11.5	10000	11400	10900	13000	12000	14800	
SGFC-600	42	3.5	4.2	13000	17000	14200	18900	15500	21000
		4	5.2	13500	17900	14700	19800	16000	21900
		4.5	6.3	14000	18600	15200	20600	16500	22800
	44	3.5	4.2	12500	15400	13500	17300	14500	19400
		4	5.2	13000	16200	14000	18200	15000	20400
		4.5	6.3	13500	16800	14400	18850	15500	21000
46	3.5	4.2	11500	13700	12700	15650	14000	17800	
	4	5.2	12000	14400	13200	16500	14500	18800	
	4.5	6.3	12500	15000	13700	17200	15000	19600	
SGFC-800	42	4.5	7.6	17500	21600	19000	24000	20500	26400
		5	9.4	18000	22300	19500	24600	21000	27200
		5.5	11	18500	22800	20000	25300	21500	28000
	44	4.5	7.6	17000	19800	17500	22000	18000	24400
		5	9.4	17500	20400	18000	22650	18500	25200
		5.5	11	18000	20900	18400	23300	19000	26000
46	4.5	7.6	15000	17400	16200	20000	17500	22600	
	5	9.4	15500	18400	16700	20800	18000	23400	
	5.4	11	16000	18800	17200	21300	18500	24100	
SGFC-1000	42	6	7	21000	27300	23000	30100	25000	33200
		6.5	8	21500	27900	23500	30800	25500	34000
		7	9	22500	28400	24200	31300	26000	34600
	44	6	7	20500	25000	21700	28000	23000	31000
		6.5	8	21000	25400	22200	28500	23500	31800
		7	9	22000	25800	22900	28800	24000	32200
46	6	7	18500	22400	20400	25400	22500	28800	
	6.5	8	19000	22800	20900	25850	23000	29200	
	7	9	19500	23300	21400	26500	23500	30000	
SGFC-1200	42	7	9	26000	34500	28000	38100	30000	42000
		7.5	10	26500	35000	28500	39000	30500	43100
		8	11.5	27500	35400	29200	39500	31000	44000
	44	7	9	25500	31400	26700	35100	28000	39200
		7.5	10	26000	32300	27200	36300	28500	40600
		8	11.5	27000	32800	28000	36700	29000	41000
46	7	9	23500	28200	25500	32100	27500	36400	
	7.5	10	24000	28700	26000	32800	28000	37200	
	8	11.5	24500	29000	26500	33100	28500	37600	

Notes :

- 1- Capacities are based on high fan speed .
- 2- For unit capacities at med. or low speed, multiply table values by the given

Motor Speed	Correction Factor
Medium	0.90
Low	0.80



HOT WATER RATINGS

MODEL	Entering Water Temperature (F)	GPM	Water Pressure Drop (FT.W.G.)	Entering Air Temperature (F)		
				68DB Heating Load (BTU/HR)	70DB Heating Load (BTU/HR)	72DB Heating Load (BTU/HR)
SGFC-200	140	2	3.6	14000	12700	11500
		2.5	5.4	14500	13200	12000
		3	7.3	15000	13700	12500
	160	2	3.6	18000	17200	16500
		2.5	5.4	18500	17700	17000
		3	7.3	19000	18200	17500
180	2	3.6	22000	21200	20500	
	2.5	5.4	22500	21700	21000	
	3	7.3	23000	22000	21500	
SGFC-300	140	3	9	19500	18700	18000
		3.5	11.4	20000	19200	18500
		4	15	20500	19700	19000
	160	3	9	25500	24500	23500
		3.5	11.4	26000	25000	24000
		4	15	26500	25500	24500
180	3	9	31500	30200	29000	
	3.5	11.4	32000	30700	29500	
	4	15	32500	31200	30000	
SGFC-400	140	3.5	11.5	24500	23700	23000
		4	15	25000	24200	23500
		4.5	18	25500	24700	24000
	160	3.5	11.5	32500	31500	30500
		4	15	33000	32000	31000
		4.5	18	33500	32500	31500
180	3.5	11.5	39000	38200	37500	
	4	15	39500	38700	38000	
	4.5	18	40000	39200	38500	
SGFC-600	140	4.5	6.3	31500	30200	29000
		5	7.5	32000	30700	29500
		5.5	9	32500	31200	30000
	160	4.5	6.3	40000	39000	38000
		5	7.5	40500	39500	38500
		5.5	9	41000	40000	39000
180	4.5	6.3	48500	47700	47000	
	5	7.5	49000	48200	47500	
	5.5	9	49500	48700	48000	
SGFC-800	140	6	12.6	41000	39700	38500
		6.5	14.5	41500	40200	39000
		7	16.2	42000	40700	39500
	160	6	12.6	52000	51000	50000
		6.5	14.5	52500	51500	50500
		7	16.2	53000	52000	51000
180	6	12.6	63500	62200	61000	
	6.5	14.5	64000	62700	61500	
	7	16.2	64500	63200	62000	
SGFC-1000	140	7.5	10	49500	48200	47000
		8	11.5	50000	48700	47500
		8.5	12.8	50500	49200	48000
	160	7.5	10	62500	61200	60000
		8	11.5	63000	61700	60500
		8.5	12.8	63500	62200	61000
180	7.5	10	76000	75000	74000	
	8	11.5	76500	75500	74500	
	8.5	12.8	77000	76000	75000	
SGFC-1200	140	8.5	12.8	58000	56700	55500
		9	13.9	58500	57200	56000
		9.5	15.2	59000	57700	56500
	160	8.5	12.8	74000	72700	71500
		9	13.9	74500	73200	72000
		9.5	15.2	75000	73700	72500
180	8.5	12.8	89500	88200	87000	
	9	13.9	90000	88700	87500	
	9.5	15.2	90500	89200	88000	

Notes :

- 1- Capacities are based on high fan speed.
- 2- For unit capacities at med. or low speed, multiply table values

Motor Speed	Correction Factor
Medium	0.90
Low	0.80

HORIZONTAL CEILING MOUNTED , EXPOSED

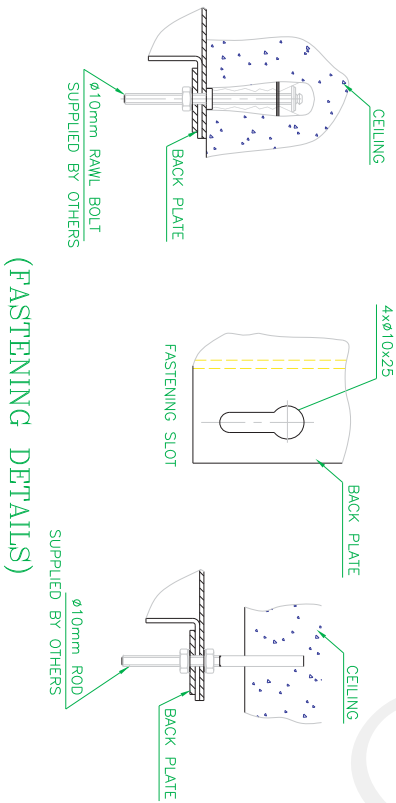
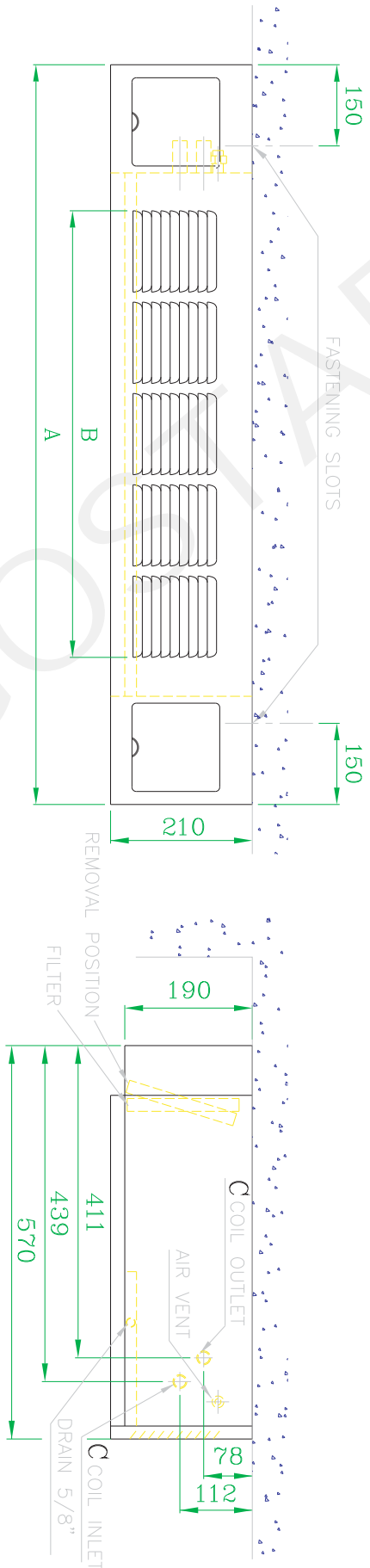

DIMENSIONS

MODEL	A	B	C
SGFC -200	920	510	1/2" MPPT
SGFC -300	1120	640	1/2" MPPT
SGFC -400	1220	780	1/2" MPPT
SGFC -600	1360	910	3/4" MPPT
SGFC -800	1620	1180	3/4" MPPT
SGFC-1000	1920	1440	3/4" MPPT
SGFC-1200	2270	1840	3/4" MPPT

Notes :

- Left handed coil connections are shown.
- To order desired model, Add proper characters to model (See nomenclature).
- All dimensions in mm.



...Fan Coils

HORIZONTAL CEILING MOUNTED , CONCEALED

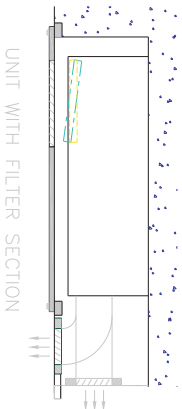
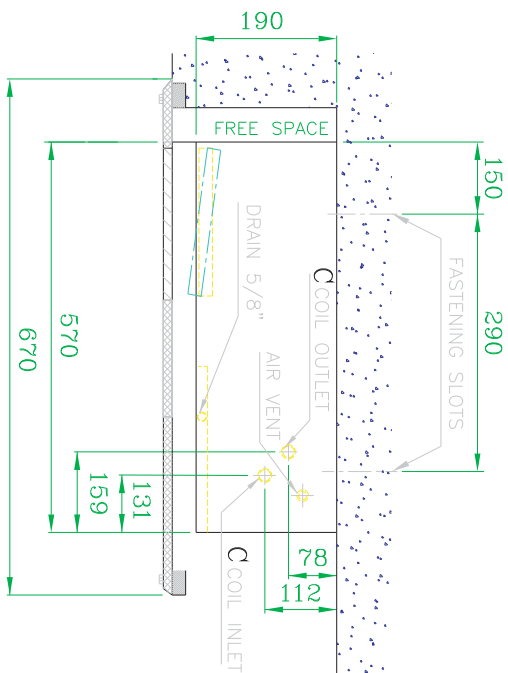
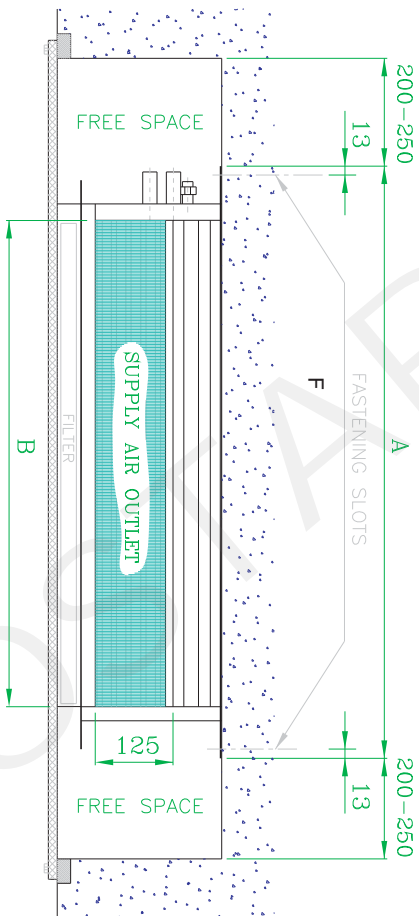

DIMENSIONS

MODEL	A	B	C
SGFC -200	650	570	1/2" MPT
SGFC -300	850	770	1/2" MPT
SGFC -400	950	870	1/2" MPT
SGFC -600	1090	1010	3/4" MPT
SGFC -800	1350	1270	3/4" MPT
SGFC -1000	1650	1570	3/4" MPT
SGFC -1200	2000	1920	3/4" MPT

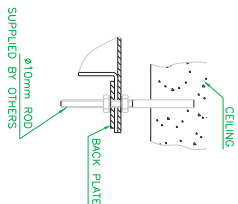
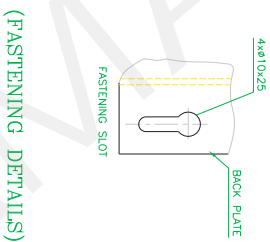
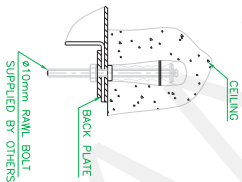

- Notes :
- Left handed coil connections are shown.
 - To order desired model. Add proper characters to model (See nomenclature).
 - All dimensions in mm.

LO - BOY

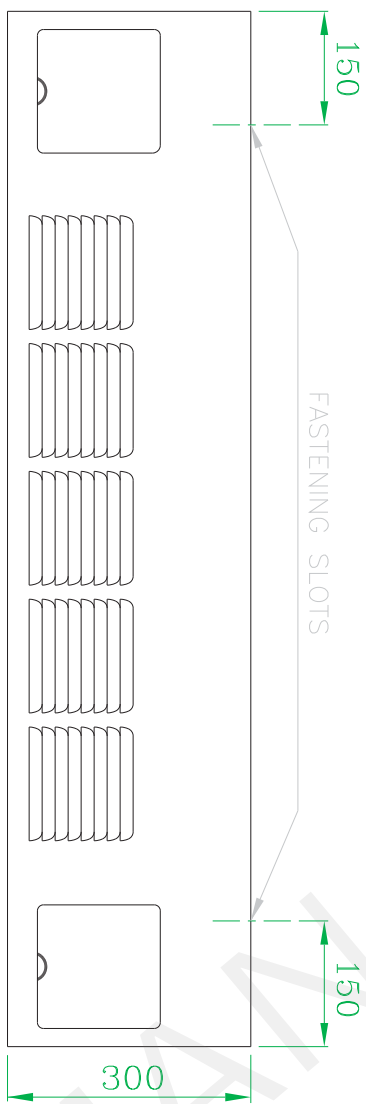
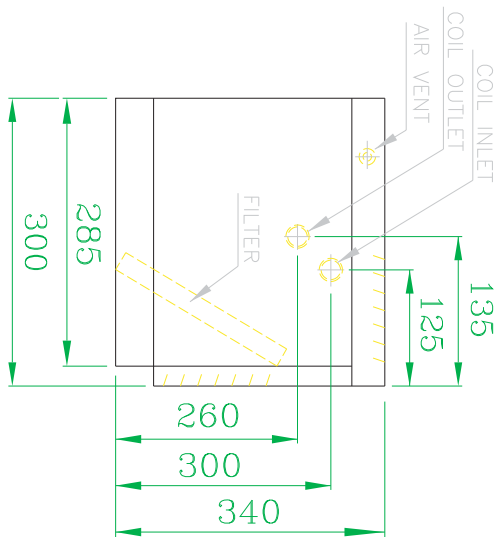
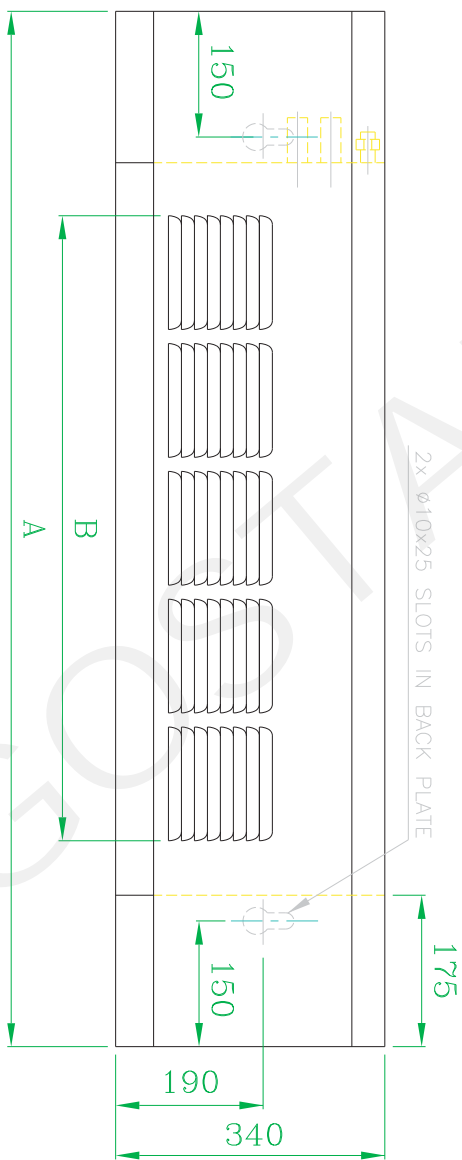

Notes :

- Left handed coil connections are shown.
- To order desired model. Add proper characters to model (See nomenclature).
- All dimensions in mm.

DIMENSIONS

MODEL	A	B	C
SGFC -200	920	510	1/2" MPT
SGFC -300	1120	640	1/2" MPT
SGFC -400	1220	780	1/2" MPT
SGFC -600	1360	910	3/4" MPT
SGFC -800	1620	1180	3/4" MPT
SGFC-1000	1920	1440	3/4" MPT
SGFC-1200	2270	1840	3/4" MPT



SLANT TOP DISCHARGE

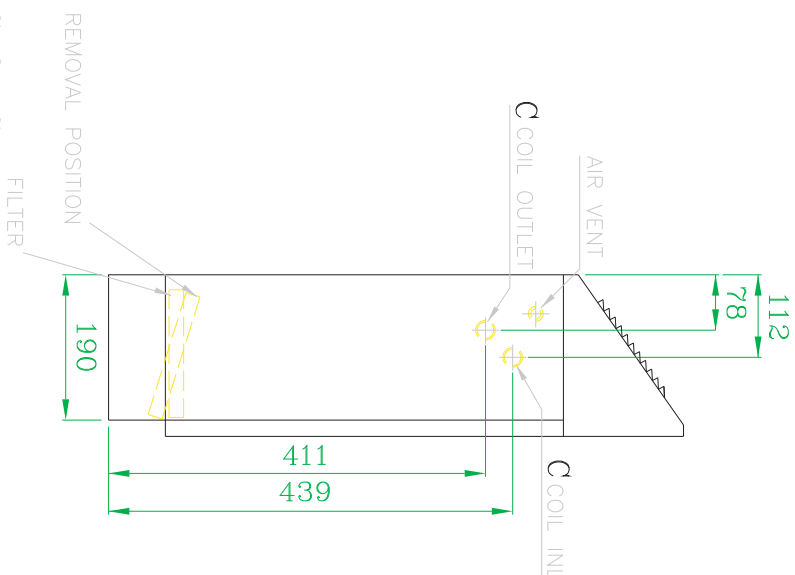
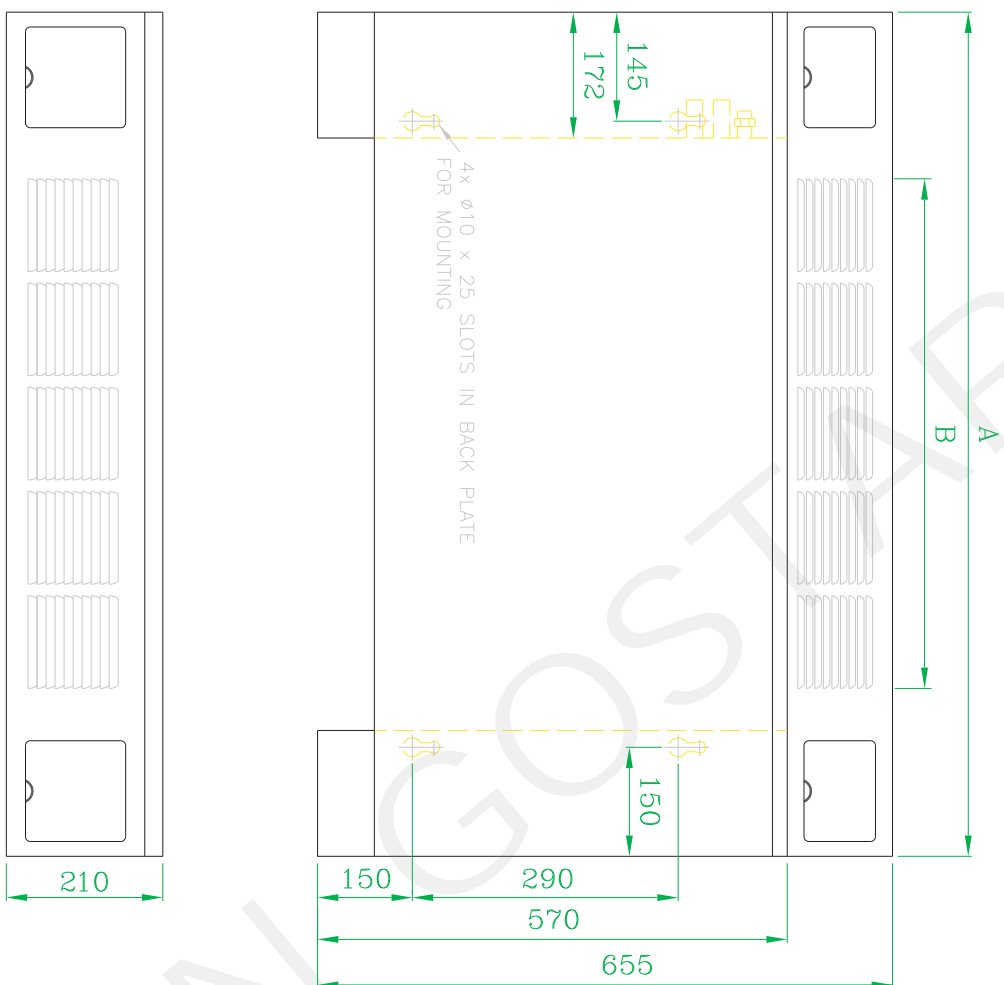

DIMENSIONS

MODEL	A	B	C
SGFC -200	920	510	1/2" MPPT
SGFC -300	1120	640	1/2" MPPT
SGFC -400	1220	780	1/2" MPPT
SGFC -600	1360	910	3/4" MPPT
SGFC -800	1620	1180	3/4" MPPT
SGFC-1000	1920	1440	3/4" MPPT
SGFC-1200	2270	1840	3/4" MPPT

Notes :

- Left handed coil connections are shown.
- To order desired model. Add proper characters to model (See nomenclature).
- All dimensions in mm.